

FITTING INSTRUCTION

Clamp mark in acc. with		Cables joining
ISO	PN	
1	L	Left directional lights
2	+	Rear fog lights
3	31	Ground
4	R	Right directional lights
5	58R	Right side parking lights
6	54	Stoptlights
7	58L	Left side parking lights

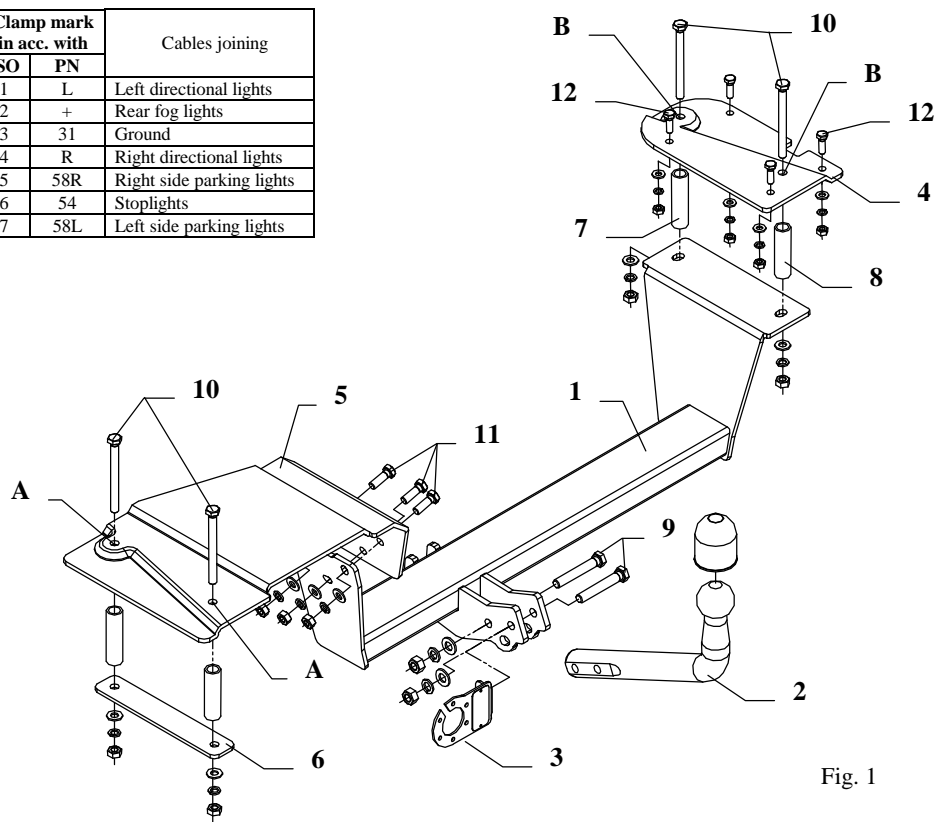

Fig. 1

This towing hitch is designed to assembly in following cars:
ALFA ROMEO 156, 4 doors, produced since 1997 till 05.2003 and
ALFA ROMEO 156 SPORTWAGON (Estate), produced since 2000 till 05.2003,
 catalogue no. **AL34** and is prepared to tow trailers max total weight **1600 kg** and max
 vertical load **60 kg**.

*The towing hitch should be install in points described by a car producer. Before
 begin installation, see maintance of car, page 191-point of towing hitch assembly.*

From manufacturer

Thank you for buying our product. Their reliability has been confirmed in many tests. Reliability of towing hitch depends also on correct assembly and right operation. For this reasons we kindly ask to read carefully this instruction and apply to hints.

The towing hitch should be install in points described by a car producer.

The instruction of the assembly

1. Take out spare wheel.
2. Remove carpet from the floor and cover panels from rear and side wall of the trunk.
3. Fig. 2 shows chassis frame from below the car: holes 1, 2 and 3 make clear, next through this holes drill $\varnothing 11\text{mm}$ to trunk (make very carefully).

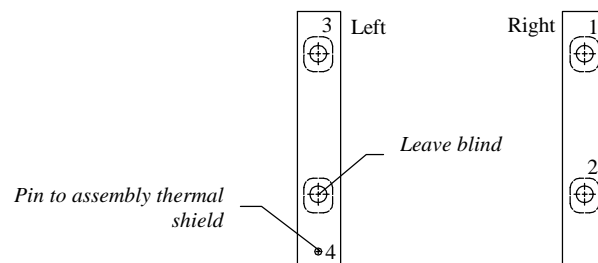

Fig. 2

4. Unscrew the nut from the pin (see fig. 2, pos. 4). Pull heat cover, next cut off pin. In place of pin drill hole $\varnothing 11\text{mm}$ straight through inside trunk (make very carefully).
5. From inside drill made holes $\varnothing 22\text{mm}$ (only in one side).
6. To in this way prepared holes slip distance sleeves $L=74\text{mm}$ (pos. 8 - to holes closer rear of car) and sleeves $L=80\text{mm}$ (pos. 7) in rest of holes - see fig. 1.
7. Place elements (pos. 4 and 5) in the trunk as shown in the fig. 1, holes (pos. A and B) of this elements must agree with made holes, put bolts M10x110mm (pos. 10).
 - Outline elements (pos. 4 and 5),
 - Disassemble above mentioned elements, cut and remove anti corrosion mat fragments,
 - Place again elements (pos. 4 and 5), place bolts M10x110mm (pos. 10).
8. Through three holes (invisible on the fig. 1) in bracket (pos. 5) drill holes $\varnothing 11\text{mm}$ straight through.
9. Through rest four holes in element (pos. 4) drill holes $\varnothing 9\text{mm}$ straight through.
10. To so prepared elements (pos. 4 and 5) put (from the bottom) the main bar of the towing hitch (pos. 1) and fix as showed on the fig. 1.
11. Fix tow-ball (pos. 2) and socket plate (pos. 3) using bolts M12x75mm (pos. 9) from towing hitch accessories.
12. Tighten all bolts according to the torque shown in the table.
13. Connect electric wires of 7-poles socket according to the instruction of the car. (Recommend to make at authorized service station)
14. Complete paint layer damaged during installation.

Torque settings for nuts and bolts (8,8):

M 8 - 25 Nm	M 10 - 55 Nm
M 12 - 85 Nm	M 14 - 135 Nm











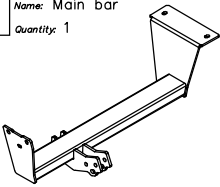
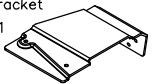

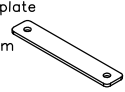

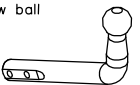

NOTE

After install the towing hitch you should get adequate note in registration book (at authorised service station).The car should be equipped with:

- Indicators
- Tow mirrors

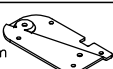
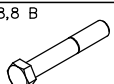
After 1000km check all screws. The ball of towing hitch must be always kept clear and conserve with a grease.

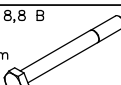
Towing hitch accessories:

Pos. 1 Name: Main bar Quantity: 1 	Pos. 5 Name: Bracket Quantity: 1 	Pos. 11 Name: Bolt 8,8 B Quantity: 3 Dim.: M10x30mm 	Pos. 17 Name: Plain washer Quantity: 7 Dim.: Ø 10,5 mm 
	Pos. 6 Name: Fish-plate Quantity: 1 Dim.: 222x40x5mm 	Pos. 12 Name: Bolt 8,8 B Quantity: 4 Dim.: M8x25mm 	Pos. 18 Name: Plain washer Quantity: 4 Dim.: Ø 8,5 mm 
Pos. 2 Name: Tow ball Quantity: 1 	Pos. 7 Name: Distance sleeve Quantity: 2 Dim.: Ø21,3x2,65mm L=80mm 	Pos. 13 Name: Nut 8 B Quantity: 2 Dim.: M12 	Pos. 19 Name: Spring washer Quantity: 2 Dim.: Ø 12,2 mm 
Pos. 3 Name: Socket plate Quantity: 1 	Pos. 8 Name: Distance sleeve Quantity: 2 Dim.: Ø21,3x2,65mm L=74mm 	Pos. 14 Name: Nut 8 B Quantity: 7 Dim.: M10 	Pos. 20 Name: Spring washer Quantity: 7 Dim.: Ø 10,2 mm 
Pos. 4 Name: Plate Quantity: 1 Dim.: 261x143x4mm 	Pos. 9 Name: Bolt 8,8 B Quantity: 2 Dim.: M12x75mm 	Pos. 15 Name: Nut 8 B Quantity: 4 Dim.: M8 	Pos. 21 Name: Spring washer Quantity: 4 Dim.: Ø 8,2 mm 
	Pos. 10 Name: Bolt 8,8 B Quantity: 4 Dim.: M10x110mm 	Pos. 16 Name: Plain washer Quantity: 2 Dim.: Ø 13 mm 	Pos. 22 Name: Ball cover Quantity: 1 



PPUH AUTO-HAK S.J.

Produkcja Zaczepów Kulowych
Henryk & Zbigniew Nejman
76-200 SŁUPSK ul. Słoneczna 16K
tel/fax (059) 8-414-414; 8-414-413
e-mail: office@autohak.com.pl
www.autohak.com.pl

Towing hitch (without electrical set)

Class: **A50-X** Cat. no. **AL34**

Designed for:

Manufacturer: **ALFA ROMEO**

Model: **156**

Type: **4 doors**

produced since 1997 till 05.2003

Type: **SPORTWAGON (Estate)**

produced since 2000 till 05.2003

Technical data:

D-value: 8,66 kN

maximum trailer weight: **1600 kg**

maximum vertical cup load: **60 kg**

Approval number according to Directive 94/20/EC: e20*94/20*0221*00

Foreword

This towing hitch is designed according to rules of safety traffic regulations. The towing hitch is a safety component and can be install only by qualified personnel. Any alteration or conversion of the towing hitch is prohibited and would lead to cancellation of design certification. Remove insulating compound and underseal from vehicle (if present) in the area of the matting surfaces of the towing hitch.

The vehicle manufacturer's specifications regarding trailer load and max. vertical cup load are decisive for driving whereat values for the towing hitch cannot be exceeded.

D-value formula:

$$\frac{\text{Max trailer weight [kg]} \times \text{Max vehicle weight [kg]}}{\text{Max trailer weight [kg]} + \text{Max vehicle weight [kg]}} \times \frac{9,81}{1000} = D \text{ [kN]}$$